

10 GALLON SANDBLASTER



SAFETY INSTRUCTIONS FOR SANDBLASTER

1、 BEFORE OPENING THE TANK, release the air pressure on the sand tank. To do this, turn off the air supply valve(19), and open the nozzle valve(19C), to release pressure in the line. Ensure that the tank pressure gauge(16) reads zero, then open the tank.

2、 MAINTAIN CORRECT AIR PRESSURE, Pressure should not exceed 125 PSI. If it does, the safety valve(11), is supposed to release the excess pressure. If this doesn't happen, stop all work immediately, and use the air compressor to reduce the excess pressure. Do not investigate the sandblaster's pressure problem until the pressure gauge(16), reads zero.

ASSEMBLING THE SANDBLASTER

1、 Refer to the drawing for step 1, assembling the intake manifold(15). First, attach the pressure gauge(16), to the top of the intake manifold, turning the gauge so that it can be seen across the top of the tank. Next, attach the throttling valve(19A) to the bottom of the manifold. Attach the nipple connector(21), to the throttling valve. Attach the joint pipe(14), to the manifold.

2、 Refer to the drawing for step 2, to assemble the water trap filter(18). Two nipple connector(17) are screwed into each side of the filter. On one side, attach the air supply valve(19), to the nipple connector(17), and then attach the male/female connector (20), to the other side of the air supply valve. When you're ready to operate the sandblaster, the air hose from the compressor will fasten to the male/female connector(20).

3、 Place the tank (01) on a table with the four clips up. Refer to the drawing for step 3. Screw the water trap filter (18) and its parts into the hole at the side of the intake manifold. Then screw the open end of the joint pipe (14) with intake manifold (15) and pressure gauge (16) attached into the threaded hole on the side of the filler pipe on top of the tank. Again, be sure that the manifold and gauge are vertical.

4、 Refer to the drawing for step 4, assembly of the sand outlet valve into the hole at the bottom of the tank. Attach four parts, in order: Nipple connector(17); sand metering valve (19B); nipple connector (17) and the sand outlet pipe (23).

5、 Refer to the drawing for step 5, assembly of the nozzle shut off valve(19C). In this assembly process, you'll select one of the four nozzles (28). This is not a permanent selection, as you may change nozzles according to the job being done. Screw the adapter-(26), into the nozzle shut off valve(19C) .Screw the last nipple connector(17) into the other side of the valve. Screw the gasket (27) into the nipple connector, then add a nozzle (28) and the nozzle cap-nut (29).

6、 Refer to the drawing for step 6, for connecting the sand metering valve assembly (step 4) and the nozzle shut off assembly (step 5). Slide the two hose clamps (24), over each end of the sand hose (25), Press one end of the hose, over the nipple on the sand outlet pipe (23), and the other end over the adapter (26). Both hose ends should be firmly seated on the nipples, Slide the hose clamps along the hose to each nipple and tighten the clamps very firmly. They have to resist the force of 65 to 125 PSI.

7、 Fasten the two handlebars (06) to the tank using four pan screws (08) and four washers(10) and four hex nuts (09) . Note: keep the handle curve ends upward.

8、 Locate the axle (05), and slide it through the holes in the sides of the handlebars (06). Place one wheel (02) at each end of the axle and fasten them into place with cotter pins (03) and washer (30).

9、 Insert the fixed foot (04) onto the fitting on the bottom of the tank near the edge. Use your last cotter pin (03) to hold the foot to the tank.

10、 Before beginning operations, go back over each connection, double checking to ensure that all are tight and properly seated.

ABRASIVE SELECTION

The kind of sand you choose will greatly influence the amount of time

needed to clean a given surface area. Sandblasting materials include silicon carbide, alumina, silica sand, bank sand, and beach sand. However, bank sand and beach sand, even if washed, will still contain shell, coral and organic materials. These absorb moisture much more readily than the other materials. As a result, the moisture in bank and beach sands frequently causes plugging of the sand metering valve.

If you elect to reuse sand, remember it does wear out. The sharp edges become rounder, and are less effective. It's at that point you should replace the batch of sand you're using.

LOADING ABRASIVES INTO THE TANK

1. Check your abrasive to be sure it's dry, and won't clog the meter valve (19B), sand outlet pipe (23), hose (25), or other components.
2. Put on the protective clothing.
3. Turn the air supply valve (19) to the off (horizontal) position.
4. Open the nozzle shut off valve (19C) (vertical position).
5. Watch the pressure gauge (16) and make sure it reads zero pressure.
6. Remove the filler cap (13) from the top of the tank.
7. Insert the funnel (30), and pour the abrasive into the funnel. Be sure to get enough into the tank to do the job at hand. But if this is a big job, fill the tank only 3/4 full, and reload as needed to finish the work.
TIP: if the humidity is 90-100%, the water trap (18) won't be able to trap all of the moisture in a 3/4 full tank. Better to reduce the amount of abrasive, load more frequently, and empty the water trap more often. This will reduce the possibility of clogging the bottom of the tank or the line.
8. With the correct amount of abrasive in the tank, and close the filler cap(13).
9. Close the nozzle shut-off valve (19C), and open the air supply valve(19).
10. Check for air leaks at the filler cap as you begin to pressurize the tank from the compressor.

MAINTENANCE

1. You should make every effort to protect your air compressor from any damage it may receive from your sandblasting work. Your best option is to keep the compressor in a room separate from the sandblaster, using a long hose to provide the PSI needed to do your work. A second choice is to keep the compressor up wind from the sandblasting, and the greater the distance between them, the better. Other than that, you should continue standard maintenance procedures for the compressor.
2. Some parts of the sandblaster will wear much more rapidly than others. The parts needing close attention carry the air/abrasive mixture, starting with the sand hose (25), and going through the metal fittings, the shut off valve (19C) and the ceramic nozzles (28).
3. If air leaks develop in any of these parts, you should stop all work, and find what needs to be repaired or replaced. When it's new, the sand hose (25) has 2 cord piles and the walls are 1/4" thick. As the interior diameter is sandblasted, this wall becomes thinner and thinner. One way to inspect the hose and other parts affected by the blasting is to put on your protective clothing. Then pressurize the system and close the nozzle shut off valve (19C). Close your hand loosely around the hose and run it up and down the hose across the fittings and nozzles. You'll be able to feel any leaks. You can also spot places in the hose where the wall is getting very thin. These show up as blisters in the hose; if you find such a blister, get a new hose immediately. If that blister breaks, the abrasive will come out of the side of the hose at 65 or more PSI.

SAVE THESE INSTRUCTIONS

You will need these instructions for the safety instructions, the operating procedures, the parts list and the warranty. Put them in a safe and dry place for future reference.

SPECIFICATIONS

Tank dimensions: 12" diameter, 20" length

Overall dimensions: 33-1/2" H × 18-3/4" L × 13" W

Weight: 40 lbs

Hose length: 10 feet

AIR SUPPLY REQUIREMENTS

Sandblasting requires a large volume of air at high pressure. The efficiency of your sandblaster can be adversely affected by the use of too small an air supply hose, insufficient air pressure or and overly large nozzle.

HOSE INTERIOR DIAMETER	HOSE LENGTH	NOZZLE INTERIOR DIAMETER	COMPRESSOR HORSEPOWER	CFM 125PSI	SAND USE PER HOUR
3/8"	50ft	0.10"	2	6	60lbs
3/8"	25ft	0.125"	4	12	100 lbs
1/2"	50ft	0.150"	7	20	150 lbs
1/2"	25ft	0.175"	10	25	200 lbs

We recommend that air pressure in the range of 65-125 PSI will provide the best results.

IM PORTANT SAFETY INSTRUCTIONS

WARNING: When using tools such as your air compressor, whether powered by electric motor or gasoline engine, basic safety precautions should always be followed to reduce the risk of fire, electric shock, and personal injury.

You should review the safety instructions for your air compressor before beginning sandblasting with this machine.

READ ALL INSTRUCTIONS BEFORE USING THIS MACHINE

- 1、KEEP THE WORK AREA CLEAN。 Cluttered areas invite injuries。
- 2、CONSIDER WORK AREA ENVIRONMENT。 Don't use sandblaster in damp, wet, or poorly lit locations。 Keep work area well lit。 Don't use compressors in the presence of flammable gases or liquids。
- 3、KEEP CHILDREN AWAY。 All children should be kept away from the work area。 Don't let them handle tools, hose or extensions cords, also。 No one should be in the area of the sandblasting who does not have the same protective equipment you are using。
- 4、DRESS PROPERLY。 Wear protective clothing because a dust and abrasive hazard exists。 As a minimum, wear the hood (included), a dust mask to prevent inhaling the material being removed, and heavy duty gloves。
- 5、PERIODICALLY INSPECT THE SAND CARRYING COMPONENTS。 These are being sandblasted on the inside whenever you use the sandblaster, and will wear much more rapidly than other components。
- 6、SECURE THE WORK。 Use clamps or a vise to hold the work if it is small or light weight。 It's safer than using your hands and it frees both hands to operate the nozzle。
- 7、DON'T OVERREACH。 Keep proper footing and balance at all times。
- 8、MAINTAIN TOOLS WITH CARE。 Follow instructions for lubricating and changing components and accessories。
- 9、DISCONNECT AIR COMPRESSOR POWER。 When not in use, before servicing, and when changing components。
- 10、AVOID UNINTENTIONAL STARTING。 Be sure the nozzle valve is in the off position when not in use。
- 11、STAY ALERT。 Watch what you are doing, use common sense。 Don't operate any machine or tool when you are tired。
- 12、REPLACEMENT PARTS。 When servicing, use only identical replacement parts。

PARTS LIST

PART	DESCRIPTION	QTY	PART	DESCRIPTION	QTY
01	TANK	1	19	BRESS AIR SUPPLY VALVE,3/8"	1
02	WHEELS	2	19A	BRASS THROTTLING VALVE,3/8"	1
03	COTTER PINS	3	19B	STEEL SAND METERING VALVE,3/8"	1
04	FOOT	1	19C	STEEL SHUT-OF VALVE, 3/8"	1
05	AXLE	1	20	MALE-FEMALE CONNECTOR	1
06	HANDLEBARS	6	21	NIPPLE CONNECTOR	1
07	HANDLE GRIPS	2	22	AIR HOSE	1
08	PAN SCREW	4	23	SAND OUTLET PIPE	1
09	HEX NUT	4	24	CLAMP	2
10	WASHER	4	25	SAND HOSE	1
11	SAFETY VALVE	1	26	ADAPTER	1
12	O-RING	1	27	GASKET	1
13	FILLER CAP	1	28	NOZZLES(SEE BELOW)	4
14	JOINT PIPE	1	29	NOZZLE CAPNUT	1
15	INTAKE MANIFOLD	1	30	WASHER	4
16	PRESSURE GAUGE	1	31	FUNNEL	1
17	NIPPLE CONNECTOR	5	32	HOOD	1
18	WATER TRAP FILTER	1			

NOZZLES: A=9/64" B=1/8" C=7/64" D=3/32"

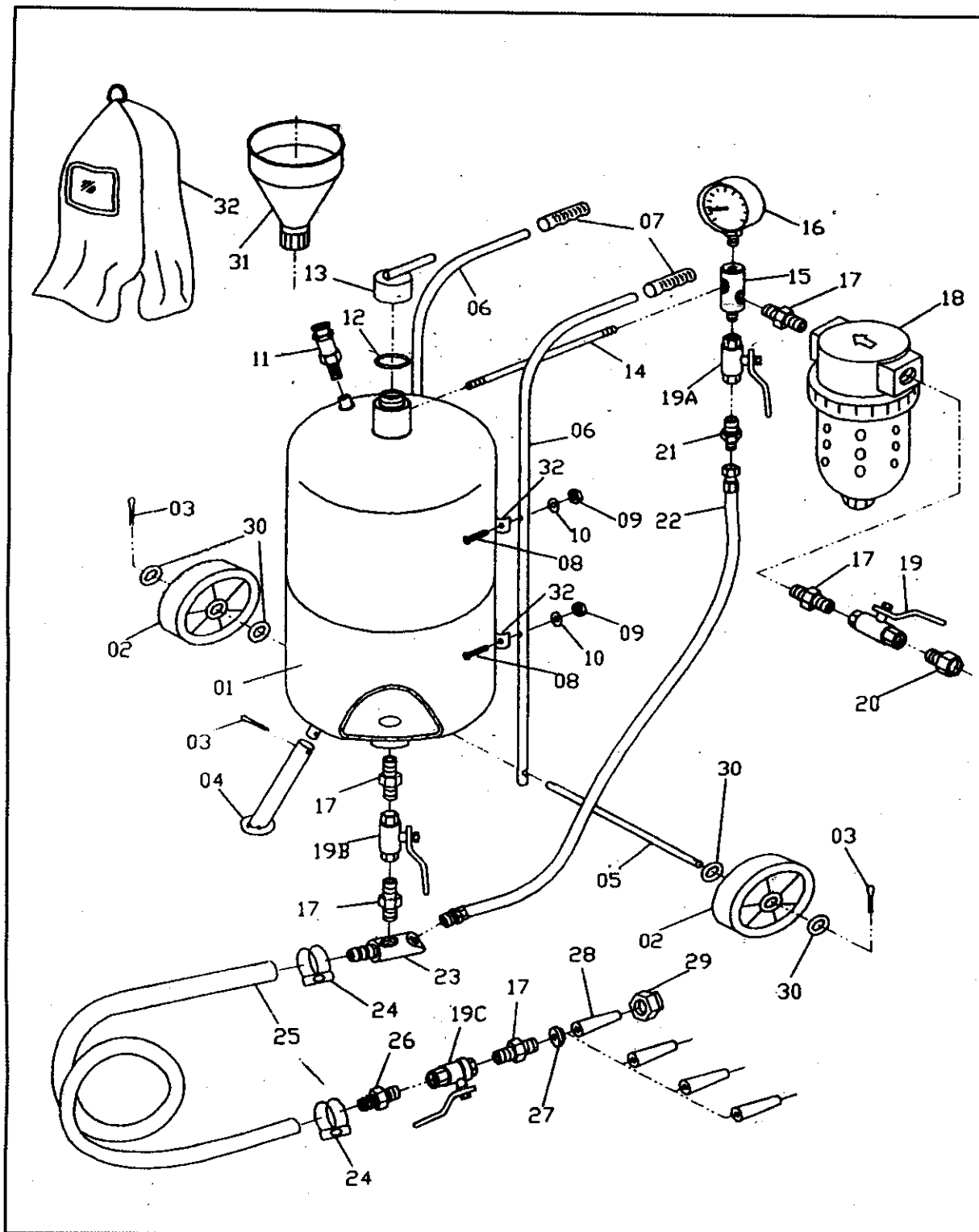

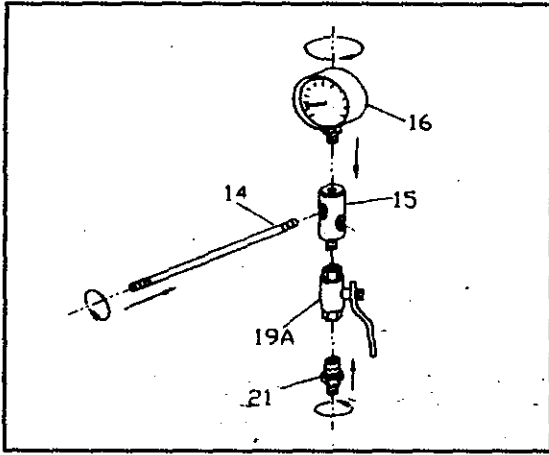

step 1

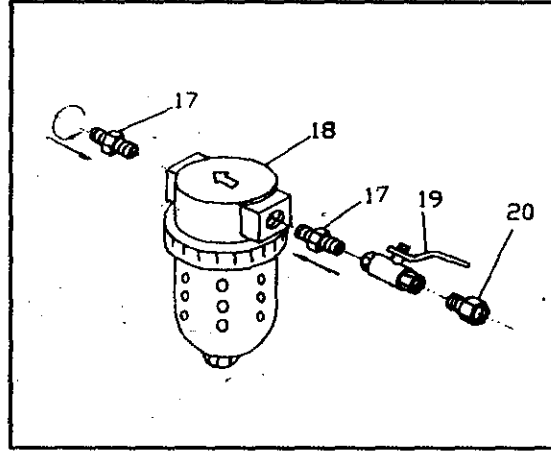

step 2

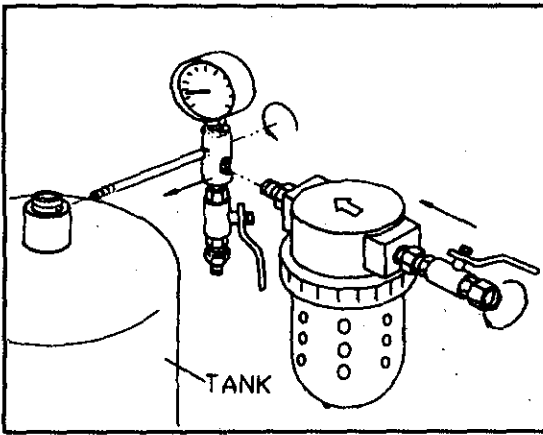

step 3

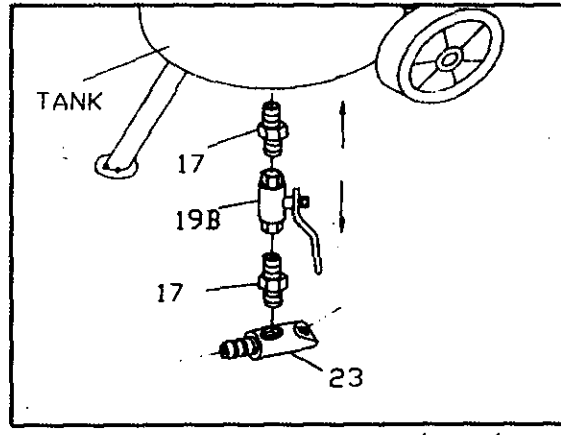

step 4

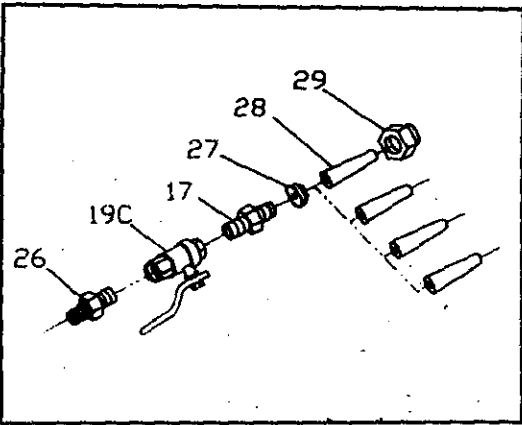

step 5

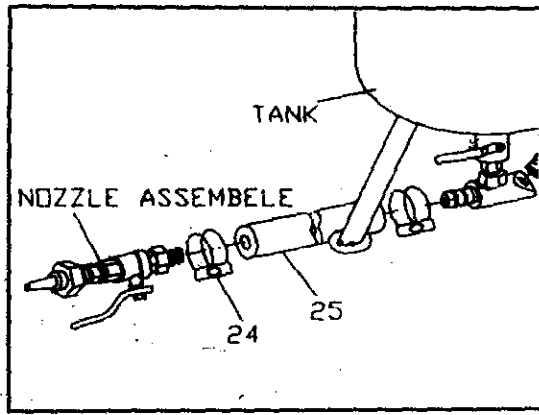

step 6

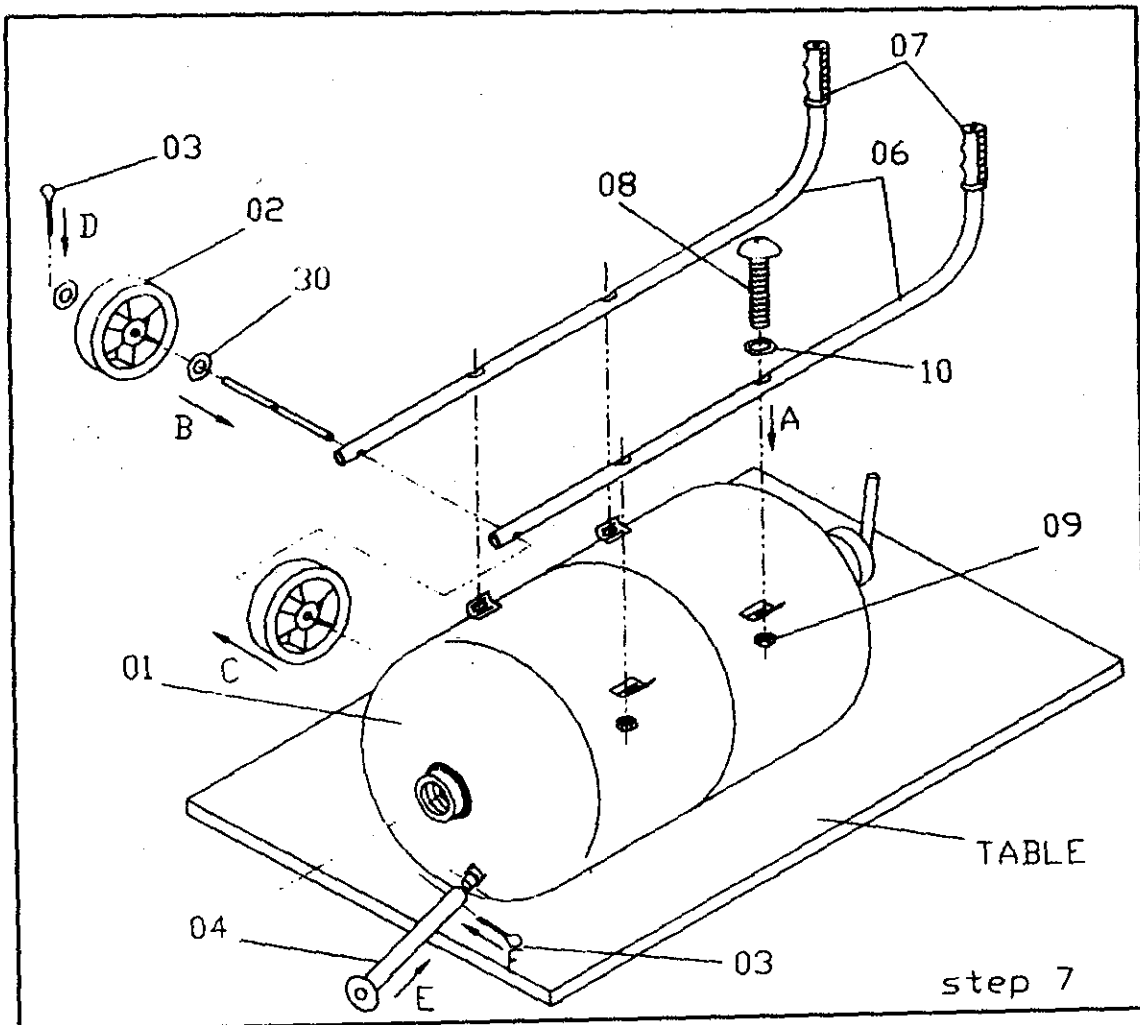

step 7