

1000

1577

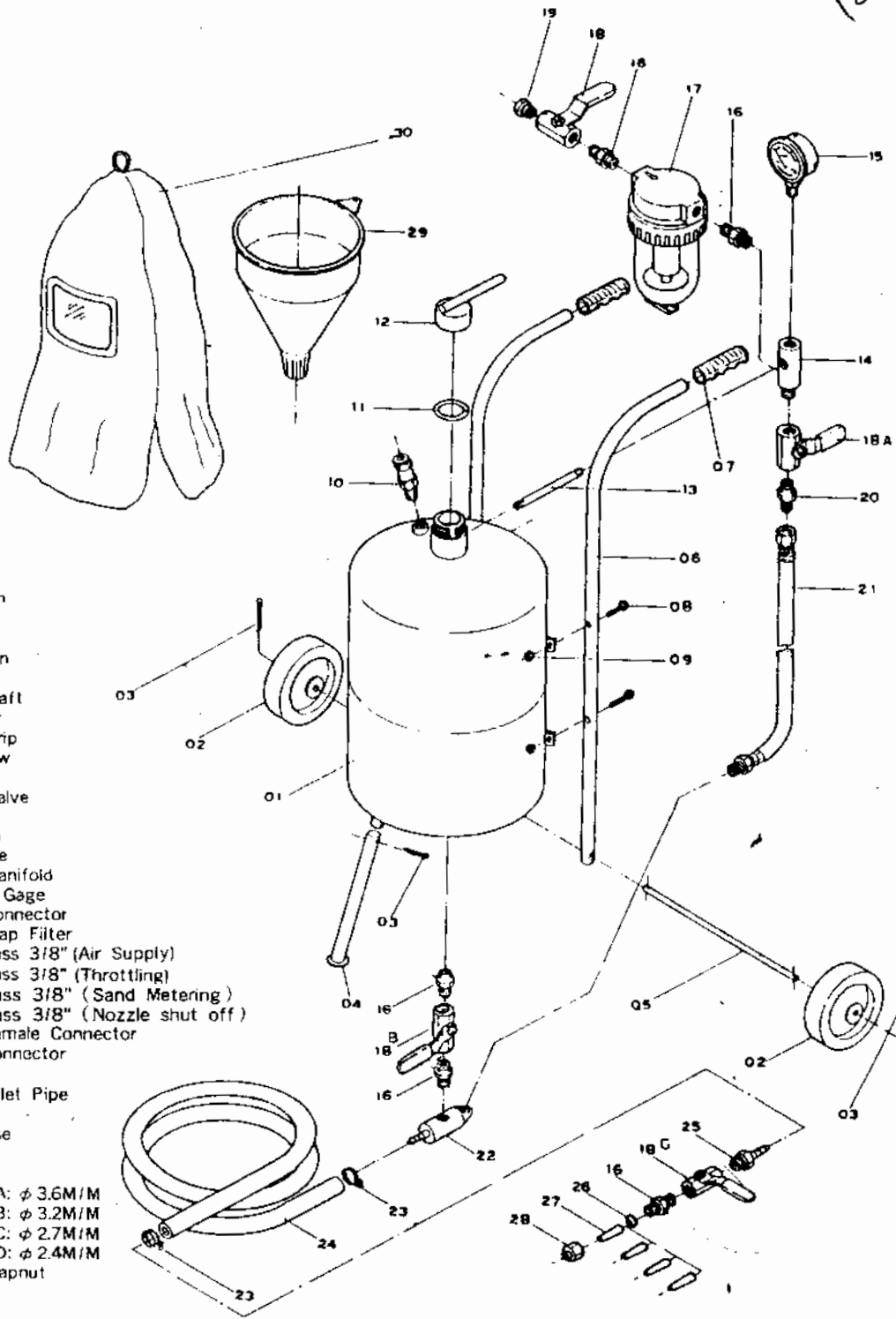

Parts List

- NO Description
- 1 Tank
- 2 Wheel
- 3 Cotter Pin
- 4 Foot
- 6 Wheel Shaft
- 6 Handlebar
- 7 Handle Grip
- 8 Pan Screw
- 9 Hex Nut
- 10 Safety Valve
- 11 O. Ring
- 12 Filler Cap
- 13 Joint Pipe
- 14 Intake Manifold
- 15 Pressure Gage
- 16 Nipple Connector
- 17 Water Trap Filter
- 18 Valve Brass 3/8" (Air Supply)
- 18A Valve Brass 3/8" (Throttling)
- 18B Valve Brass 3/8" (Sand Metering)
- 18C Valve Brass 3/8" (Nozzle shut off)
- 19 Male / Female Connector
- 20 Nipple Connector
- 21 Air Hose
- 22 Sand Outlet Pipe
- 23 Clamp
- 24 Sand Hose
- 25 Adaptor
- 26 Gasket
- 27 Nozzles: A: ϕ 3.6M/M
B: ϕ 3.2M/M
C: ϕ 2.7M/M
D: ϕ 2.4M/M
- 28 Nozzle Capnut
- 29 Funnel
- 30 Hood

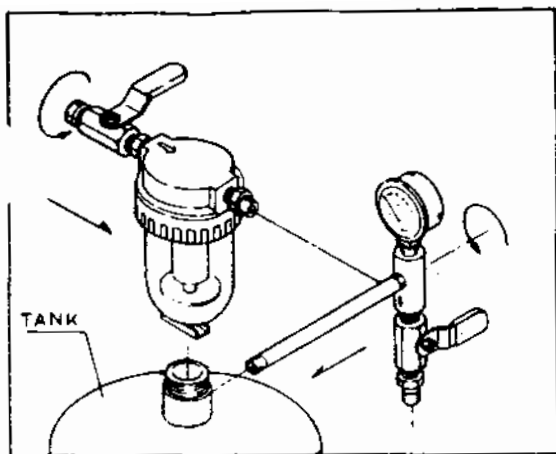

step 4

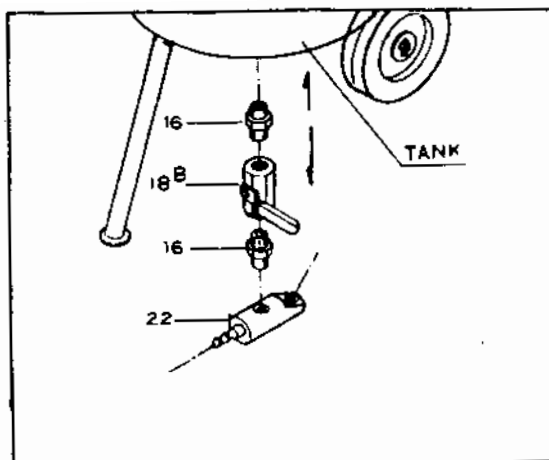

step 5

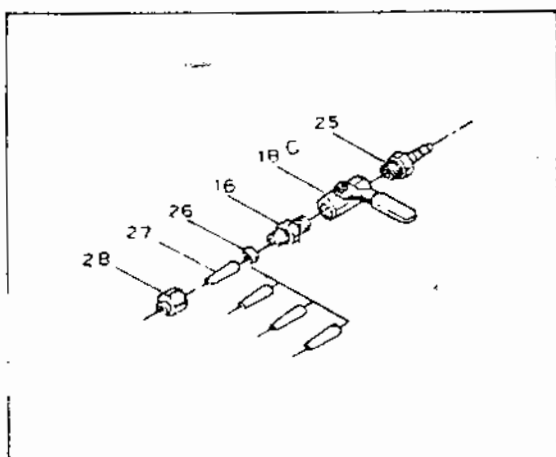

step 6

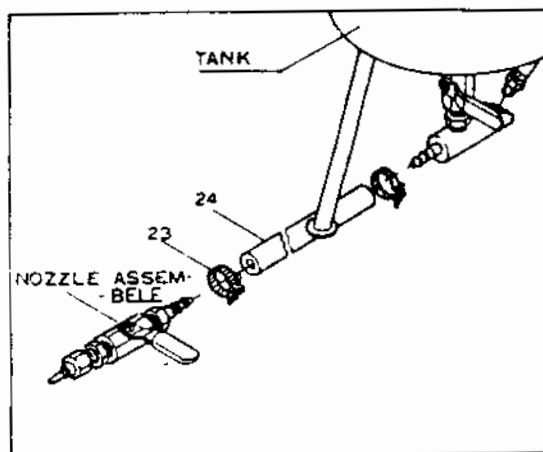

step 7

PARTS ASSEMBLE

- A. FIRST. OPEN THE BOX. FOR YOU OWN SAFETY READ MANUAL BEFORE SAND BLASTER
- B. TAKE EVERY THREAD PARTS ON TAPE SEAL
- C. STEP1: TAKE TANK ON THE TABLE. PUT(06) ON(01),AND ASSEMBLE (06) (01) AND FIX WITH (08) (09).
THAN.PUT (05) INTO (06),AND PUT (02) INTO (05),AND PUT(03) INTO (05).
THAN.TAKE (04) PUT INTO THE TANK, ASSEMBLE WITH (03).
- D. STEP2: ASSEMBLE WATER TRAP FILTER.
- E. STEP3: ASSEMBLE INTAKE MANIFOLD.
- F. STEP4: ASSEMBLE WATER TRAP FILTER & INTAKE MANIFOLD.
- STEP5: ASSEMBLE SAND OUTLET VALVE.
- STEP6: ASSEMBLE SAND BLOWING NOZZLE.
- STEP7: ASSEMBLE SAND HOSE.

A LOW AIR PRESSURE PROBLEM CAN BE ESTABLISHED BY OBSERVING TANK PRESSURE GAUGE(15) READS ABOVE 65PSI WITH VALVE (18C) CLOSED. READ AGAIN WITH VALVE (18C) OPEN IF PRESSURE DROPS BELOW 65PSI THE AIR SUPPLY IS TOO LOW IN PRESSURE.

NOZZLES INCREASE IN I.D. THRU SAND BLAST ACTION. SIMPLE REPLACEMENT OF NOZZLE WITH ONE OF SMALLER I.D. WILL INCREASE SAND BLAST EFFICIENCY.

367

YOUR AIR COMPRESSOR

PROTECT YOUR AIR COMPRESSOR AND ITS ENGINE OR MOTOR FROM DAMAGE BY SAND OR DUST FROM SANDBLASTING BY
A. KEEPING COMPRESSOR UP-WIND OF SANDBLASTER
B. IN ROOM SEPARATE FROM SANDBLASTING ROOM.

WEAR INSPECTION & PARTS REPLACEMENT

THE PARTS OF YOUR SANDBLASTER THAT REQUIRE FREQUENT WEAR INSPECTION & OCCASIONAL REPLACEMENT ARE THOSE PARTS CARRYING THE AIR-SAND MIXTURE STARTING WITH THE 8 FOOT SAND BLAST HOSE (24) AND ONWARD THRU THE METAL FITTINGS, VALVE ASSEMBLY (18C) AND CERAMIC NOZZLE.

AIR LEAKS IN ANY OF THESE PARTS INDICATE AN OBVIOUS NEED FOR REPAIR. THE SAND HOSE HAS 2 CORD PLYS AND WALL THICKNESS OF 1/4" WHEN NEW, AS ITS I.D. IS SANDBLASTED AWAY THE WALL BECOMES THINNER. ONE WAY TO INSPECT THE HOSE, WHILE WEARING PROTECTIVE CLOTHING, IS WITH UNIT UNDER PRESSURE AND VALVE (18C) CLOSED RUN YOUR HAND THE LENGTH OF THE HOSE, A SPOT OF ENLARGED DIAMETER INDICATES A WEAKENED CONDITION AND HOSE SHOULD BE REPLACED.

SAND BLASTER CAUTION

THERE IS NO HAZARD IN USE OF THIS SANDBLASTING EQUIPMENT WHEN IT IS USED PROPERLY; OBSERVE AND INSURE THAT OTHERS OBSERVE THE SAFETY PRECAUTIONS LISTED. 4072

MAXIMUM WORKING PRESSURE IS 125PSI, BEFORE CONNECTING AIR SUPPLY TO YOUR SANDBLASTER CHECK THE AIR COMPRESSOR TO INSURE THAT PRESSURE IS REGULATED IN RANGE OF 65-125PSI. OBSERVE PRESSURE GAUGE (15) INSURING IT STABILIZES BELOW 125 PSI.

WEAR PROTECTIVE CLOTHING WHENEVER A DUST & ABRASIVE HAZARD EXISTS. PROTECTIVE CLOTHING AT A MINIMUM CONSISTS OF HOOD, DUST MASK AND GLOVES. PROTECT YOURSELF WHILE LOADING SAND TANK, WHILE SANDBLASTING AND AFTER COMPLETION OF BLASTING UNTIL NO DUST IS VISIBLE IN THE AIR.

ALLOW NO PERSON IN WORK AREA WHO IS NOT WEARING PROTECTIVE CLOTHING.

FOLLOW OPERATION & SAFETY INSTRUCTIONS PRINTED ON SIDE OF TANK.

PERIODICALLY INSPECT SAND CARRYING COMPONENTS (22,24,18c, 16,26,28) FOR WEAR. THESE ARE BEING SANDBLASTED ON THE INSIDE WHENEVER YOU USE THE SANDBLASTER. REPLACE BEFORE FAILURE OCCURS.

RELEASE AIR PRESSURE ON SAND TANK BEFORE OPENING TANK. TO DO THIS TURN OFF VALVE (18), OPEN SANDBLAST NOZZLE VALVE (18c) TO LET OFF PRESSURE. INSURE TANK PRESSURE GAUGE READS ZERO, THEN OPEN TANK.

AIR SUPPLY

SANDBLASTING REQUIRES A LARGE VOLUME OF AIR AT HIGH PRESSURE, MAKE SURE YOU DON'T LIMIT THE EFFICIENCY OF YOUR UNIT BY USE OF TOO SMALL AN AIR SUPPLY HOSE.

HOSE I.D.	LENGTH FT	NOZZLE I.D.	COMPRESSOR H.P.	AIR 125PSI C.F.M.	SAND USAGE #/HR
3/8"	50	0.10"	2	6	60
"	25	0.125"	4	12	100
1/2"	50	0.150"	7	20	150
"	25	0.175"	10	25	200

YOUR SANDBLASTER WILL OPERATE PROPERLY WITH AIR PRESSURE IN THE RANGE OF 65-125 PSI.

ABRASIVE SELECTION

THE KIND OF SAND YOU CHOOSE WILL HAVE A LARGE INFLUENCE ON TIME REQUIRED TO BLAST CLEAN A GIVEN SURFACE AREA. SAND IS NOT ANY SPECIAL MATERIAL IT MEANS ONLY SMALL PARTICLES OF ROCK OR MIXTURE OF ROCKS. THE SIZE FOR SANDBLASTING WOULD BE OF A SIZE LIKE TABLE SALT.

567



SAND BLAST MATERIALS LIST

SILICON CARBIDE
ALUMINA
SILICA SAND
BANK SAND*
BEACH SAND*

*BANK SAND & BEACH SAND EVEN IF WASHED HAVE ENOUGH SHELL, CORAL & ORGANIC MATERIALS MIXED IN THAT THEY ABSORB MOISTURE READILY AND ACCOUNTS FOR THESE MATERIALS FREQUENTLY PLUGGING UP THE SAND METERING VALVE (18B).

WHEN REUSING SAND REMEMBER IT DOES "WEAR OUT" THE SHARP EDGES "ROUND UP" THATS WHEN YOU REPLACE THE BATCH.

LOADING ABRASIVES

1. CHECK YOUR ABRASIVE, IS IT DRY ENOUGH?
2. PUT ON PROTECTIVE CLOTHING
3. TURN AIR SUPPLY VALVE (18) TO OFF 
4. TURN SANDBLAST NOZZLE VALVE (18C) TO ON 
5. OBSERVE PRESSURE GAUGE (15) TO INSURE IT INDICATES ZERO PRESSURE.
6. REMOVE FILLER CAP (12)
7. INSERT FUNNEL (29) AND LOAD ABRASIVE IN AMOUNT REQUIRED TO DO JOB BUT ONLY TO MAXIMUM OF 3/4 FULL.
TIP: WHEN OPERATING IN 90-100% RELATIVE HUMIDITY THE WATER TRAP WON'T GET ALL THE MOISTURE, IN THIS CONDITION IT IS BETTER TO LOAD LESS ABRASIVE, MORE FREQUENTLY, TO REDUCE CHANCE OF ABRASIVE PACKING (BLOCKAGE) AT BOTTOM OF TANK.
8. CLOSE TANK WITH FILLER CAP (12)
9. CLOSE BLAST NOZZLE VALVE (18C)
10. OPEN AIR SUPPLY VALVE (18)
11. CHECK FOR AIR LEAK AT FILLER CAP
12. OPERATE WHEN PRESSURE REACHES MINIMUM OF 65 PSI.

1000
6077

SAND BLASTER CAUTION

THERE IS NO HAZARD IN USE OF THIS SANDBLASTING EQUIPMENT WHEN IT IS USED PROPERLY; OBSERVE AND INSURE THAT OTHERS OBSERVE THE SAFETY PRECAUTIONS LISTED.

MAXIMUM WORKING PRESSURE IS 125PSI, BEFORE CONNECTING AIR SUPPLY TO YOUR SANDBLASTER CHECK THE AIR COMPRESSOR TO INSURE THAT PRESSURE IS REGULATED IN RANGE OF 65-125PSI. OBSERVE PRESSURE GAUGE (15) INSURING IT STABILIZES BELOW 125 PSI.

WEAR PROTECTIVE CLOTHING WHENEVER A DUST & ABRASIVE HAZARD EXISTS. PROTECTIVE CLOTHING AT A MINIMUM CONSISTS OF HOOD, DUST MASK AND GLOVES. PROTECT YOURSELF WHILE LOADING SAND TANK, WHILE SANDBLASTING AND AFTER COMPLETION OF BLASTING UNTIL NO DUST IS VISIBLE IN THE AIR.

ALLOW NO PERSON IN WORK AREA WHO IS NOT WEARING PROTECTIVE CLOTHING.

FOLLOW OPERATION & SAFETY INSTRUCTIONS PRINTED ON SIDE OF TANK.

PERIODICALLY INSPECT SAND CARRYING COMPONENTS(22,24,18c,16,26,28) FOR WEAR. THESE ARE BEING SANDBLASTED ON THE INSIDE WHENEVER YOU USE THE SANDBLASTER. REPLACE BEFORE FAILURE OCCURS.

RELEASE AIR PRESSURE ON SAND TANK BEFORE OPENING TANK. TO DO THIS TURN OFF VALVE(18), OPEN SANDBLAST NOZZLE VALVE (18c) TO LET OFF PRESSURE. INSURE TANK PRESSURE GAUGE READS ZERO. THEN OPEN TANK.

AIR SUPPLY

SANDBLASTING REQUIRES A LARGE VOLUME OF AIR AT HIGH PRESSURE. MAKE SURE YOU DON'T LIMIT THE EFFICIENCY OF YOUR UNIT BY USE OF TOO SMALL AN AIR SUPPLY HOSE.

HOSE I.D.	LENGTH FT	NOZZLE I.D.	COMPRESSOR H.P.	AIR 125PSI C.F.M.	SAND USAGE #/HR
3/8"	50	0.10"	2	6	60
"	25	0.125"	4	12	100
1/2"	50	0.150"	7	20	150
"	25	0.175"	10	25	200

YOUR SANDBLASTER WILL OPERATE PROPERLY WITH AIR PRESSURE IN THE RANGE OF 65-125 PSI.

SANDBLAST STARTUP

1. CHECK VALVES TO BE PROPERLY SET.
AIR SUPPLY (18) "OFF"
THROTTLING (18A) OPEN
SAND METERING (18B) HALF OPEN
NOZZLE VALVE (18C) CLOSED
2. PUT ON PROTECTIVE CLOTHING
3. TURN AIR SUPPLY VALVE (18) TO "ON"
4. POINT NOZZLE AT WORK SO THAT SAND WILL STRIKE SURFACE AT ABOUT 45 DEGREE
5. QUICKLY MOVE NOZZLE VALVE(18C) TO FULL OPEN.
 - 5.1. KEEP THE NOZZLE MOVING TO CHANGE IMPACT PATTERN ON THE WORKPIECE TO ENSURE UNIFORM ABRADING OVER THE WHOLE WORK AREA.
 - 5.2. THE FLOW RATE OF SAND MAY BE IRREGULAR WHEN THE UNIT IS FIRST STARTED. BUT IF SAND IS DRY THE FLOW WILL EVEN UP IN A MINUTE OR TWO.
 - 5.3. TO INCREASE OR DECREASE SAND FLOW RATE ADJUST SAND METERING VALVE (18B)
 - 5.4. TO REGULATE TOTAL AIR FLOW & PRESSURE AT NOZZLE ADJUST THROTTLE VALVE (18A)

SANDBLASTER SHUTDOWN

1. TURN NOZZLE VALVE (18C) QUICKLY TO FULL CLOSED POSITION.
2. TURN SAND METERING VALVE TO CLOSED POSITION.
3. OPEN NOZZLE VALVE (18C) QUICKLY TO FULL OPEN POSITION UNTIL ALL SAND HAS CLEARED FROM SAND HOSE (24).
4. CLOSE NOZZLE VALVE (18C) QUICKLY.
5. TURN AIR SUPPLY VALVE (18) TO CLOSED POSITION.
6. OPEN NOZZLE VALVE (18C) TO DE-PRESSURIZE THE SANDBLASTER.
7. NOW YOU CAN GET OUT OF THE PROTECTIVE CLOTHING.

TROUBLE SHOOTING

POOR OR IRREGULAR PERFORMANCE OF YOUR SANDBLASTER IS DUE TO WET SAND, LOW AIR VOLUME, LOW AIR PRESSURE OR WORN OUT NOZZLE.

MOISTURE IN THE SAND IN SUFFICIENT QUANTITY WILL CAUSE THE SAND TO STOP FLOWING THRU THE SAND METERING VALVE (18B)

- A. USE DRY SAND. CHECK BY LAYING NEWSPAPER ON DRY SURFACE AND DUMPING 6" CONE OF SAND ON THE PAPER, AFTER A FEW MINUTES REMOVE SAND. IF PAPER IS MOIST DON'T USE THE SAND.
- B. DRAIN COMPRESSOR RECEIVER TANK OF WATER REGULARLY.
- C. DRAIN WATER TRAP (17) REGULARLY.