

AIR UNDERCOATING GUN

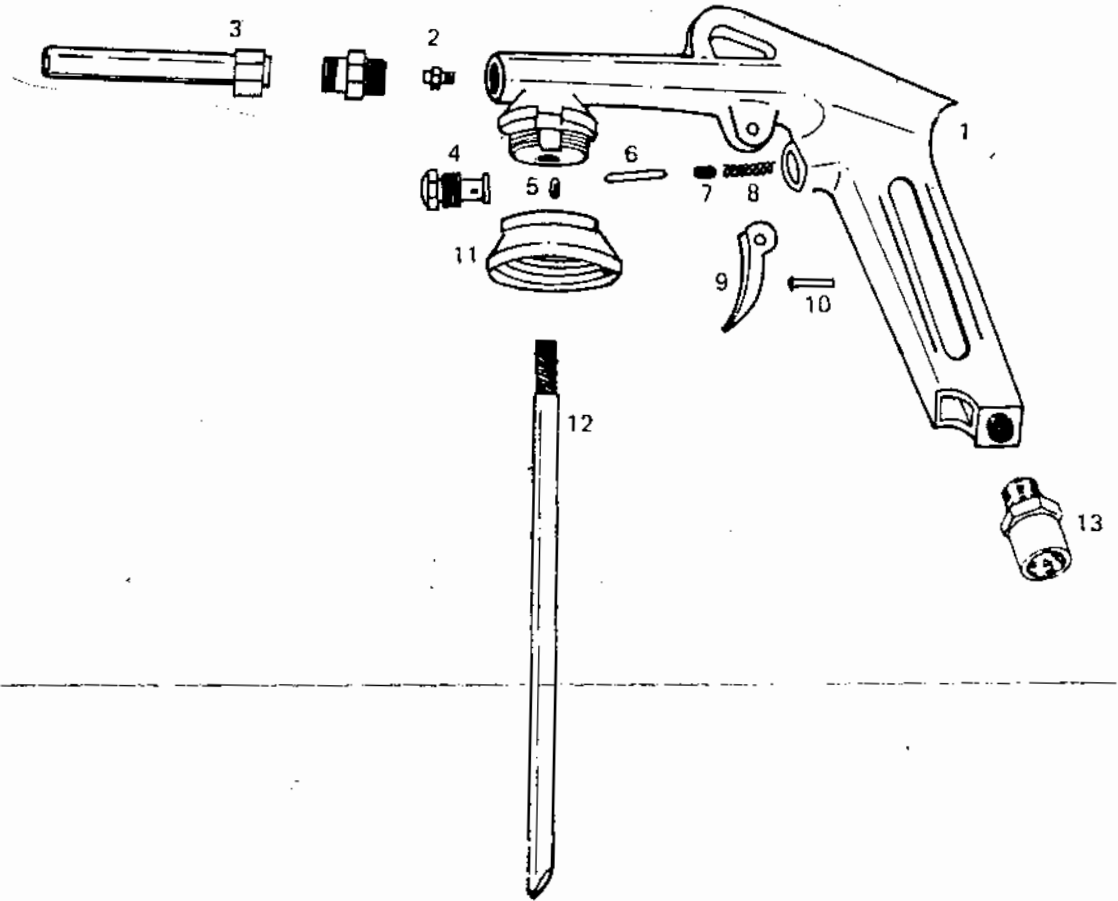

AIR CONSUMPTION11CFM
 OPERATING PRESSURE..... 55-70PSI
 NET WEIGHT..... 0.35KGS
 OVERALL LENGTH 9-1/4"
 AIR INLET..... 1/4"NPT
 HOSE SIZE..... 3/8"

Part No.	Description	No. Q'ty
1	Body	1
2	Fluid Nozzle	1
3	Nose Bece	1
4	Valve Housing	1
5	"O" Ring	1
6	Stem	1
7	Valve Ball	1
8	Throttle Spring	1
9	Trigger	1
10	Rivet	1
11	Adaptor	1
12	Fluid Tube (Length 206m/m)	1
13	Air Inlet Bushing.	1
14	Hose	1

Net 3.00