

# ORBITAL FINISH SANDER

**STOCK NO.**  
**679**

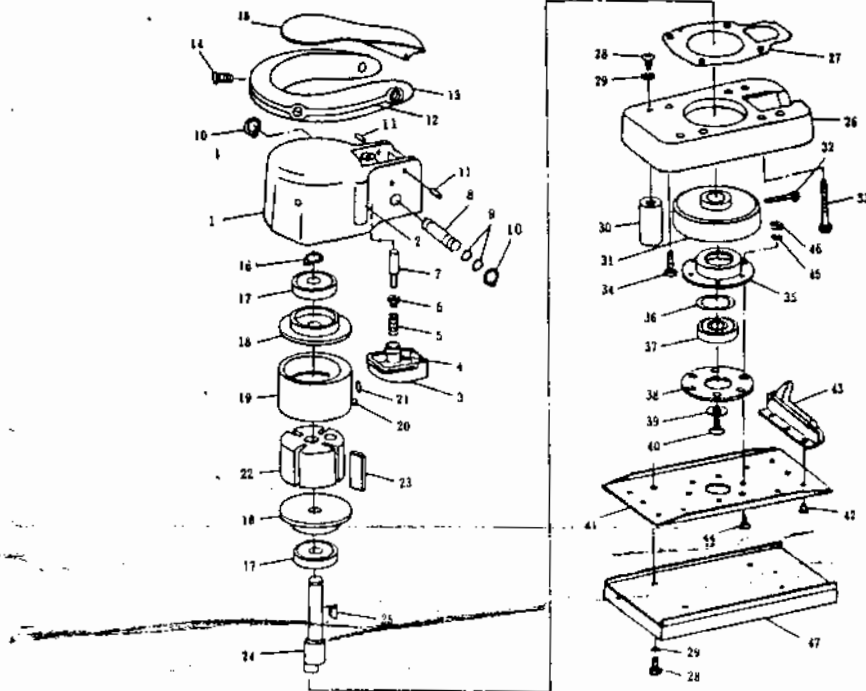

**PARTS LIST**

Index No.	Description	Qty. Per tool	Index No.	Description	Qty. Per tool
1	Motor Housing	1	25	Rotor Key	1
2	Foam Muffling	2	26	Base	1
3	Muffer	1	27	Gasket	1
4	Foam Muffling	1	28	Mount Screw	8
5	Spring	1	29	Lock Washer	8
6	Throttle Valve	1	30	Rubber Mount	4
7	Plunger	1	31	Balancer	1
8	Speed Regulator	1	32	Balancer Lock Screw	1
9	"O" Ring	2	33	Cap Screw (L)	2
10	Retaining Ring	2	34	Cap Screw (S)	2
11	Lever Pin	2	35	Bearing Housing	1
12	Grip Band	1	36	Wave Washer	1
13	Hubber Grip	1	37	Ball Bearing (6200DDu)	1
14	Grip Screw	4	38	Bearing Ret. Plate	1
15	Lever	1	39	Washer	1
16	Retaining Ring	1	40	Shaft Lock Screw	1
17	Ball Bearing	2	41	Shoe Plate	1
18	End Plate	2	42	Clamp Rivet	6
19	Cylinder	1	43	Paper Clamp Assy	2
20	Locating Pin	1	44	Bearing Hing. Screw	6
21	"O" Ring	1	45	Lock Washer	6
22	Rotor	1	46	Bearing Hing. Nut	6
23	Rotor Blade	4	47	Sanding Pad	1
24	Rotor Shaft	1			